



TD-103 - BRIC Application Specification

©Chief Enterprises 2022
Rev: 14-MAR-2023

May not be distributed or reproduced without written permission

Page 2/33

WWW.CHIEFENT.COM

Table of Contents

Description of Product:	Page 3
Configurations:	Page 4
Basic Dimensions:	Page 6
Mounting:	Page 7
Assembly Instructions:	Page 9
Disassembly Instructions:	Page 21
Terminal Systems:	Page 24
Electrical & Environmental:	Page 28
Temperature Derating:	Page 29
Validation Testing:	Page 30
Accessories & Options:	Page 31
Custom Laser Marking:	Page 33

Description of Product

Chief Enterprises' BRIC Power Distribution Module (PDM) houses plug-in electrical components such as Fuses (Mini, ATO, Maxi), Relays (280, ISO, Maxi), Circuit Breakers, Diodes, and similar components, in a sealed chamber. The PDM is designed for use in construction, agriculture, and heavy duty transportation applications where ruggedness is required.

Chief BRIC PDMs are available as fixed 280-style plug in, or in configurable assemblies called BRIC Fusion, which houses higher amperage components. BRIC Fusion uses sonic welding to combine separate inserts into an environmentally sealed base. By using separate inserts, 19 unique combinations are available.

A minimal PDM consists of a Base and Cover. Wire leads with terminals and single wire seals (SWS) are inserted in the bottom of the base, and unused cavities are plugged. Electrical components are mated to the terminals from the top of the base, and a cover with integrated compression gasket is assembled from the top. The cover is secured to the base with snap-fits.

Covers are available with and without a hydrophobic vent. The vent allows a small air flow in/out of the sealed chamber to relieve pressure differentials from component heating. In applications with low heat generation and minimal water exposure, the vent may not be required. For more demanding applications, the vent will prevent gasket blow-by and water intrusion into the sealed chamber.

The PDM can be pre-wired before mounting, or wired after mounting. The PDM should be rigidly secured using two M6 screws, fastening to integrated steel M6 nuts in the base.

Accessories such as TPAs, CPAs, Labels, and Tethers are available, and can be specified as needed. Our Engineering team can assist in selecting the components.

While the design of the PDM has been highly engineered and tested, each application can have unique characteristics that affect its functionality. Recommendations in this document are based on typical configurations and applications, but cannot cover the extent of all uses. We recommend that OEMs test the PDM in their configuration, with the specified electrical components and environmental requirements.

Configurations



24 Way



48 Way



84 Way



Fusion



Custom

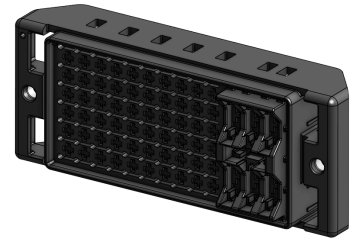

Cover with Vent



without Vent



with CPA



without CPA

BRIC Fusion Configurations

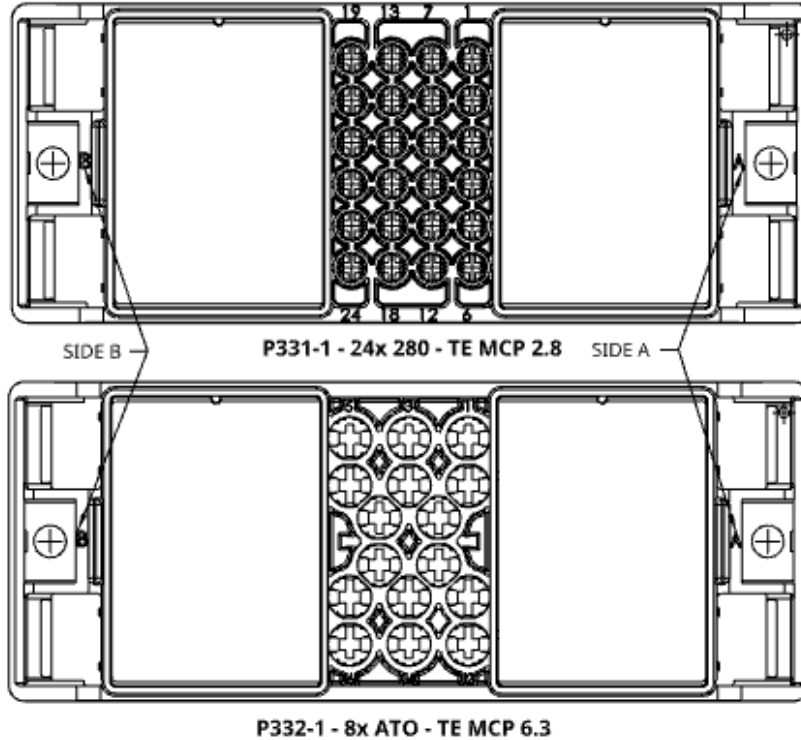

PART NUM	SIDE B	CENTER	SIDE A	USE P345 QTY
C1233	P580-1	P331-1	P582-1	2
C1228	P581-1	P331-1	P582-1	4
C1234	P583-3	P331-1	P582-1	-
C1179	P580-1	P331-1	P580-1	4
C1165	P581-1	P331-1	P580-1	6
C1235	P583-3	P331-1	P580-1	2
C1236	P581-3	P331-1	P581-1	8
C1237	P583-3	P331-1	P581-1	4
C1238	P583-3	P331-1	P583-3	-
C1107	P582-1	P332-1	P582-1	-
C1239	P580-1	P332-1	P582-1	2
C1240	P581-1	P332-1	P582-1	4
C1241	P583-3	P332-1	P582-1	-
C1242	P580-1	P332-1	P580-1	4
C1243	P581-1	P332-1	P580-1	6
C1244	P583-3	P332-1	P580-1	2
C1245	P581-1	P332-1	P581-1	8
C1246	P583-3	P332-1	P581-1	4
C1247	P583-3	P332-1	P583-3	-

Basic Dimensions

(reference only - see drawings for dimensions and tolerances)

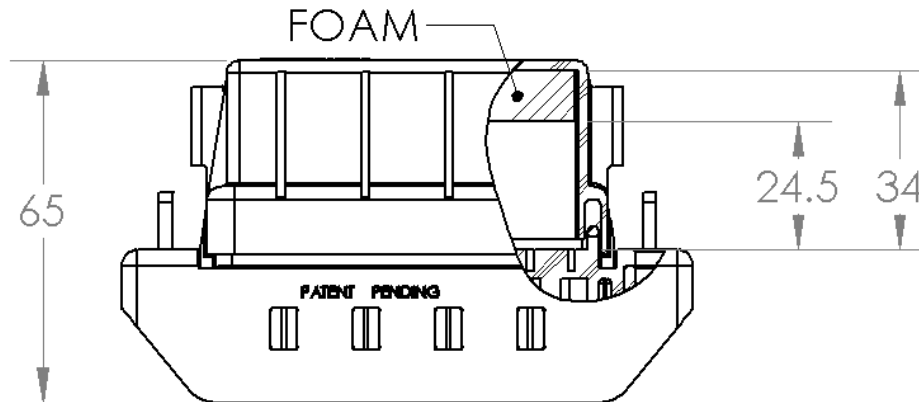
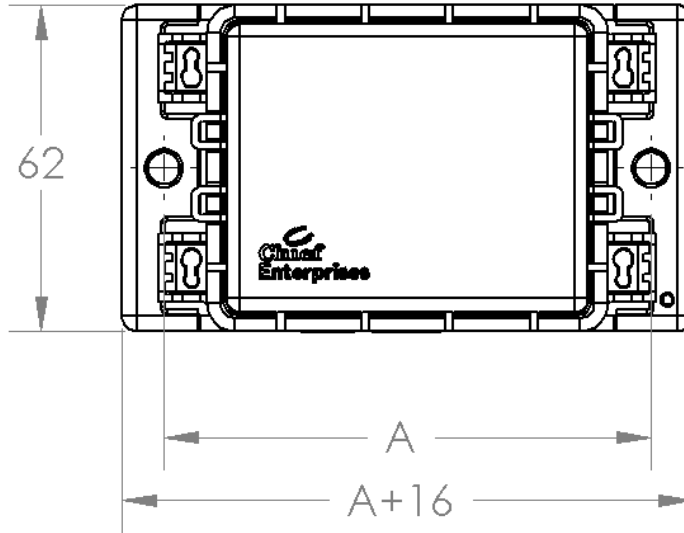

PDM Size	A
24 Way	61.3
48 Way	92.5
84 Way	139.3
Fusion	139.3

Mounting

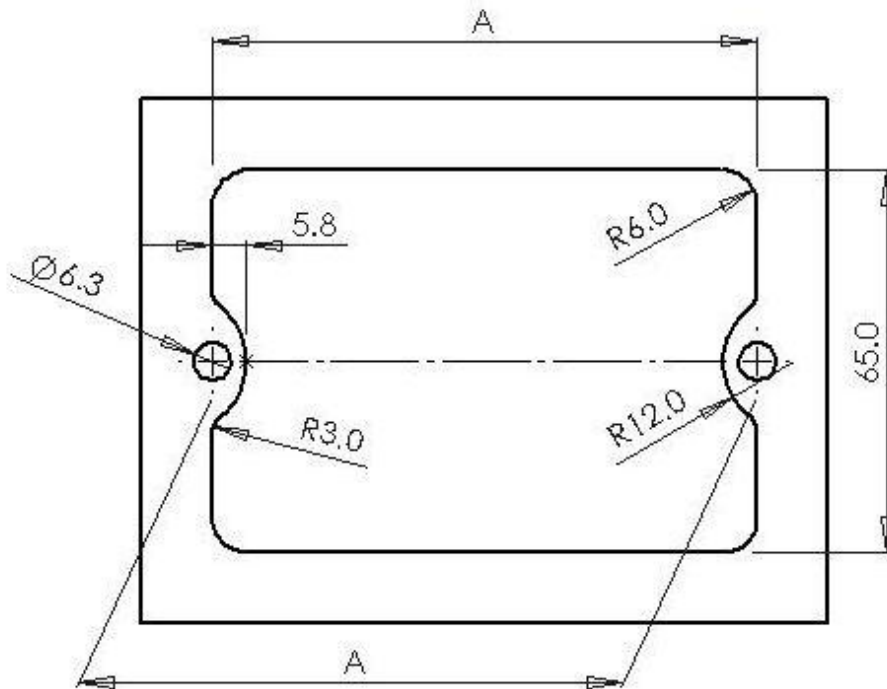
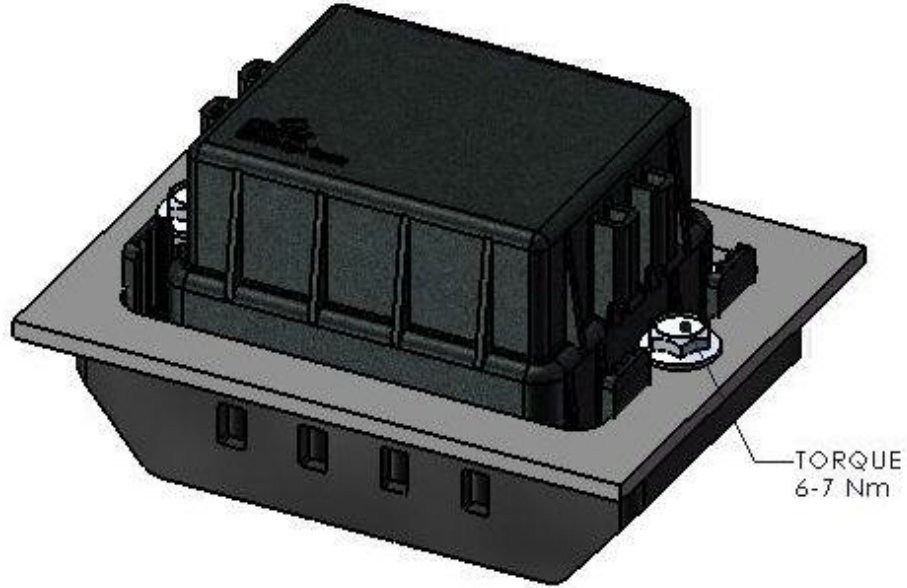

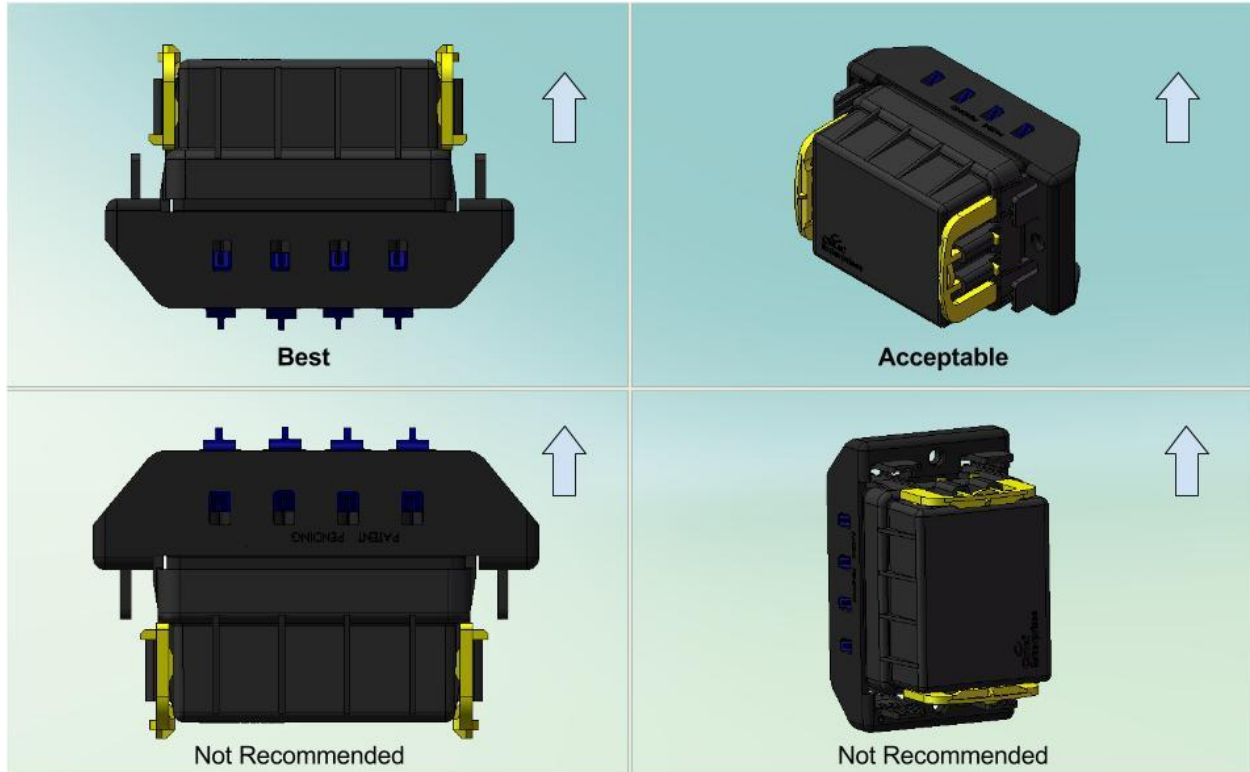

*arrow indicates upward direction

Base Poka-Yoke

The base may be assembled in two orientations. If necessary, use a location pin or sensor to orient the PDM with the 2.0 mm hole.



Assembly Instructions

Installing the cover into the base:

There are multiple ways to engage the cover into the base, but there are two methods that are recommended by Chief.

Method 1

The first method involves pushing on the Yellow CPA on the ends of the cover. With the CPA in its unlocked position, push on the middle of the CPA until the two corner locking clips are locked into place. A distinct clicking sound will be made when the cover locking clips are properly engaged. Repeat this process on the other end of the cover to fully engage it to the base. See the picture below demonstrating this method.

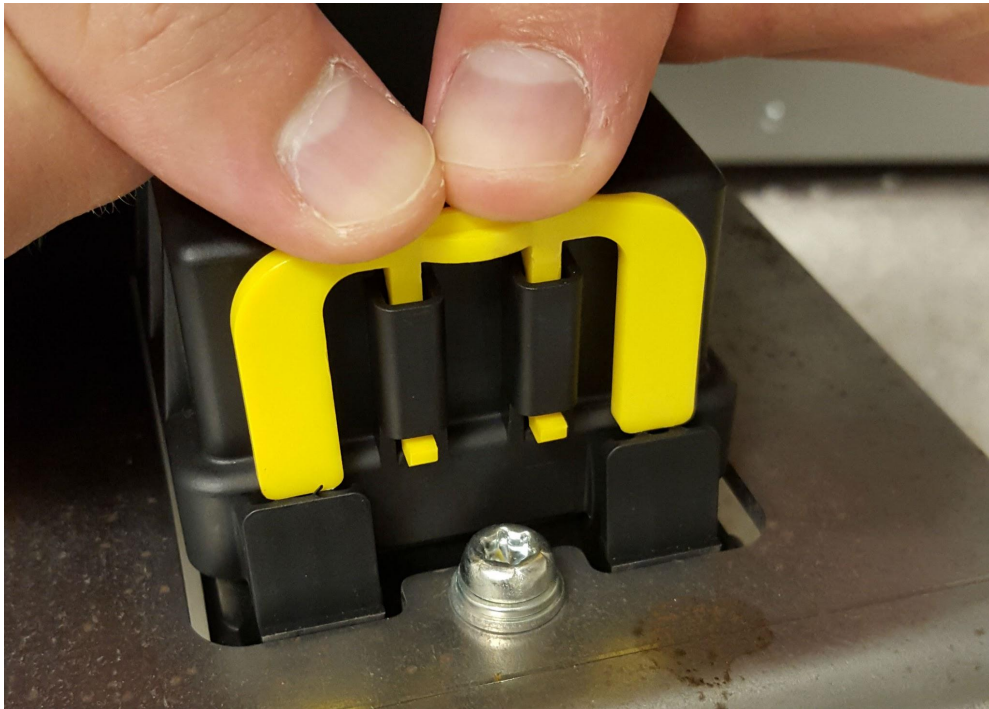

Method 2

The second method involves pushing on the cover while the Yellow CPA is already in its locked position. Make sure the CPA's are in their locked position (see CPA locking method section). Starting at one end of the cover, push down on each corner until the locking clips are fully engaged into its place on the base, making a distinct clicking sound. Repeat this process on the other end of the cover to fully engage the cover. See the picture below demonstrating this method properly.

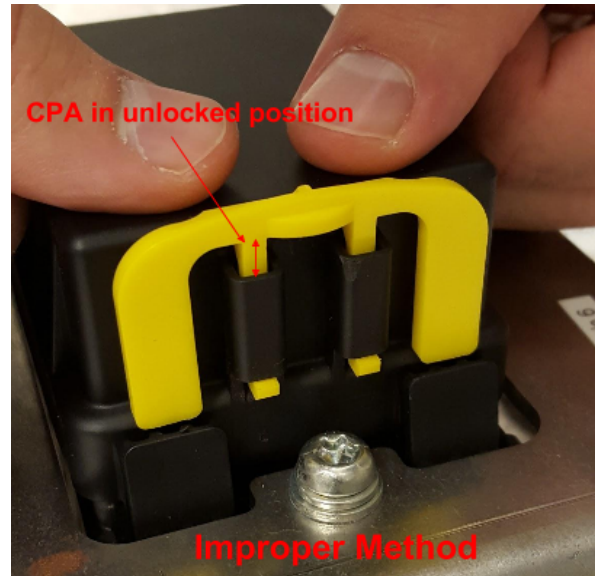
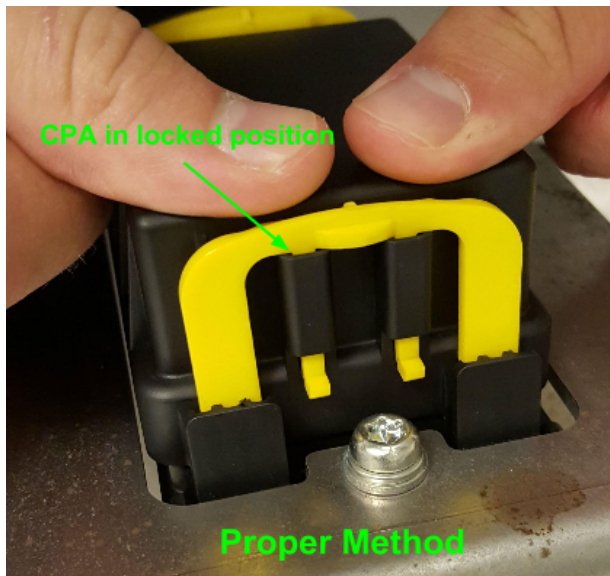

Installing the 280 TPA

The 280 TPA shall be installed after all wires or plugs are assembled into the base. Each TPA has slots that line up over each wire cavity that house the wire itself. Before attempting to engage the TPA into the base, line up the wires with their designated slots on the TPA. Once the wires are lined up in their respective slots on the TPA, push the ends in so they are able to slide down into the base. Push down on the TPA until the ledge on each end snaps into its place on the base and locks in. A screwdriver or other tool may be needed to ensure the TPA is fully engaged. See pictures below demonstrating these steps. To ensure proper installation, confirm the ledge on the TPA is flush with the surface in its locking position on the base on each side. See pictures below for examples of what it should look like when the TPA is properly installed.

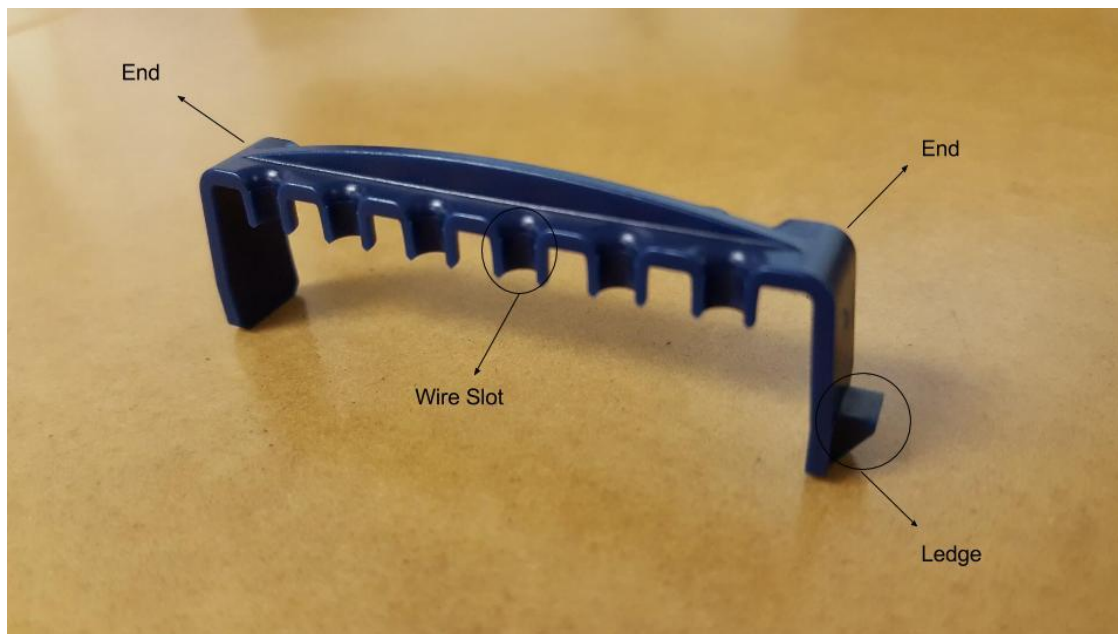

Lining up the wires in the wire slots on the TPA:



Ends pushed in and sliding into base:

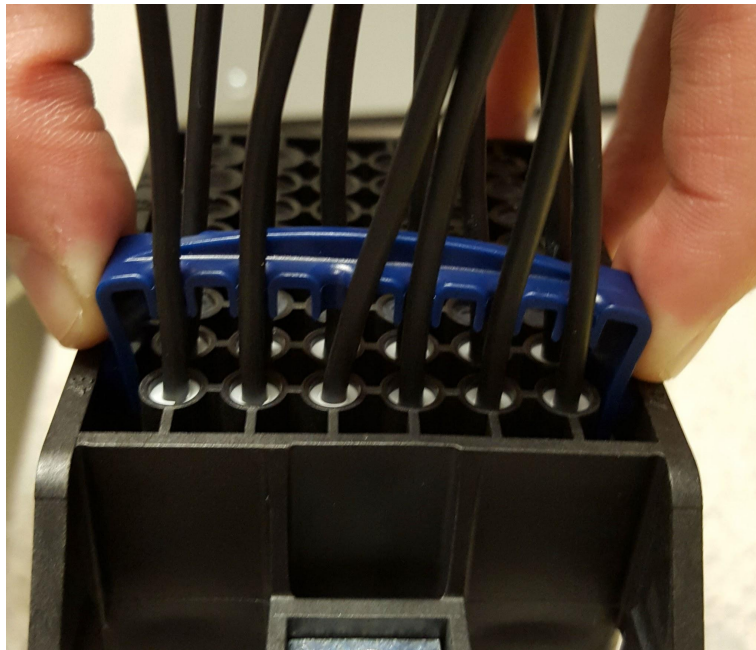

Screwdriver being used to aid in installation:



Improper Installation



Proper Installation

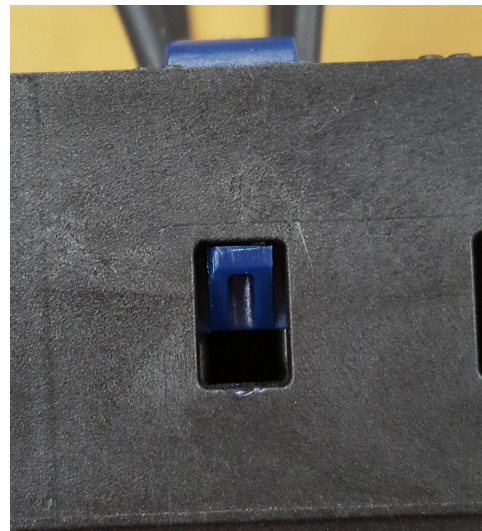

Installing the P1049 TPA

The P1049 TPA shall be installed after all wires or plugs are assembled into the base. Each TPA has slots that line up over each wire cavity that house the wire itself. Before attempting to engage the TPA into the base, line up the wires with their designated slots on the TPA. Once the wires are lined up in their respective slots on the TPA, push the ends in so they are able to slide down into the base. Push down on the TPA until the ledge on each end snaps into its place on the base and locks in. A screwdriver or other tool may be needed to ensure the TPA is fully engaged. See pictures below demonstrating these steps. To ensure proper installation, confirm the ledge on the TPA is flush with the surface in its locking position on the base on each side. See pictures below for examples of what it should look like when the TPA is properly installed.

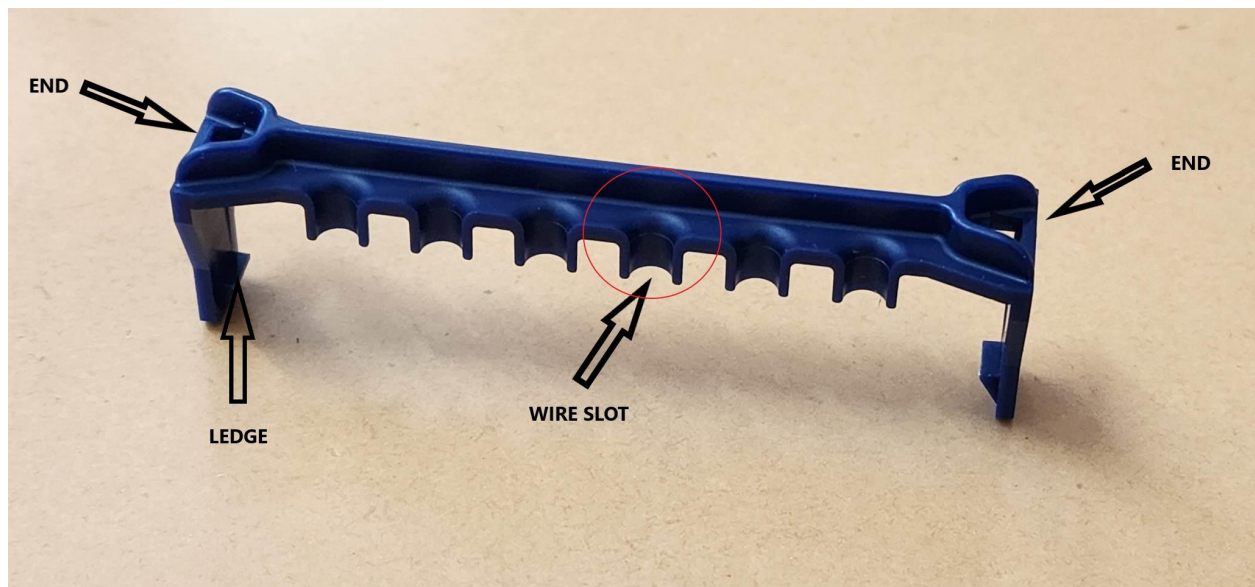

Lining up the wires in the wire slots on the TPA:

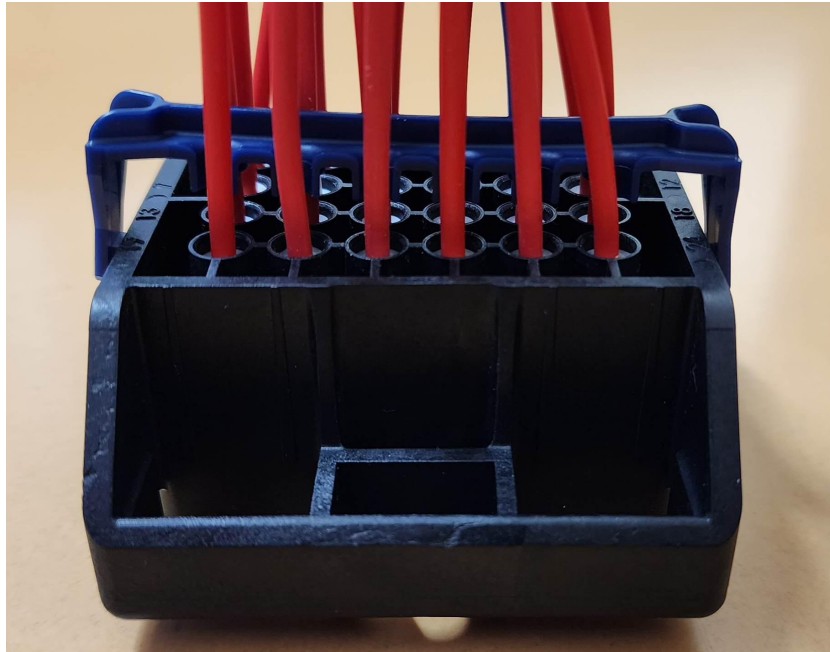

Ends pushed in and sliding into base:

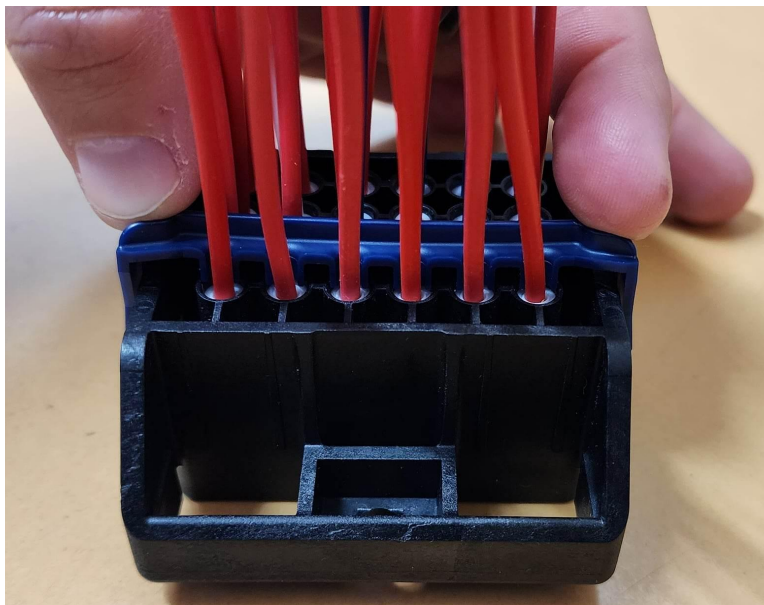

Screwdriver being used to aid in installation:

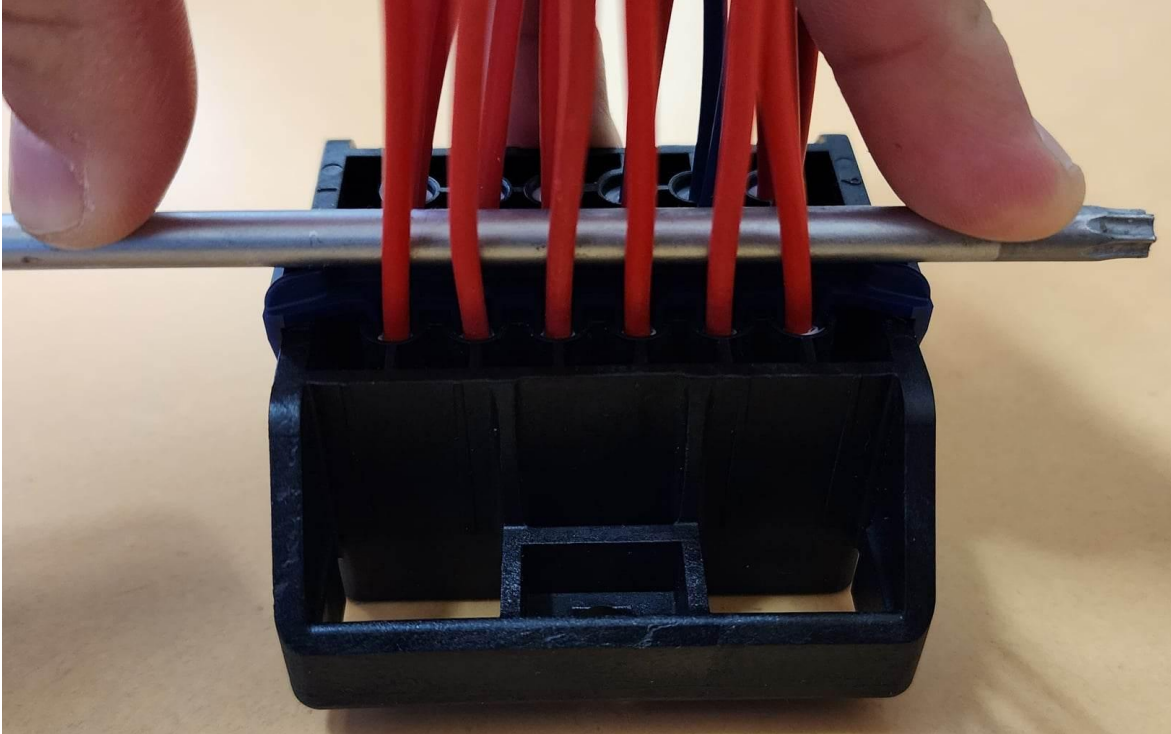

Improper Installation



Proper Installation

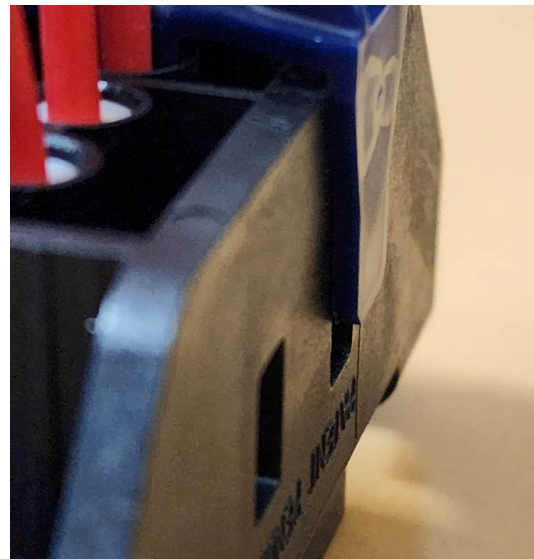

Installing the P345 TPA - BRIC Fusion

The P345 TPA shall be installed after all wires or plugs are assembled into the base. Each TPA has slots that line up over each wire cavity that house the wire itself. Before attempting to engage the TPA into the base, line up the wires with their designated slots on the TPA. Once the wires are lined up in their respective slots on the TPA, push the ends in so they are able to slide down into the base. Push down on the TPA until the ledge on each end snaps into its place on the base and locks in. A screwdriver or other tool may be needed to ensure the TPA is fully engaged. See pictures below demonstrating these steps. To ensure proper installation, confirm the ledge on the TPA is flush with the surface in its locking position on the base on each side. See pictures below for examples of what it should look like when the TPA is properly installed.

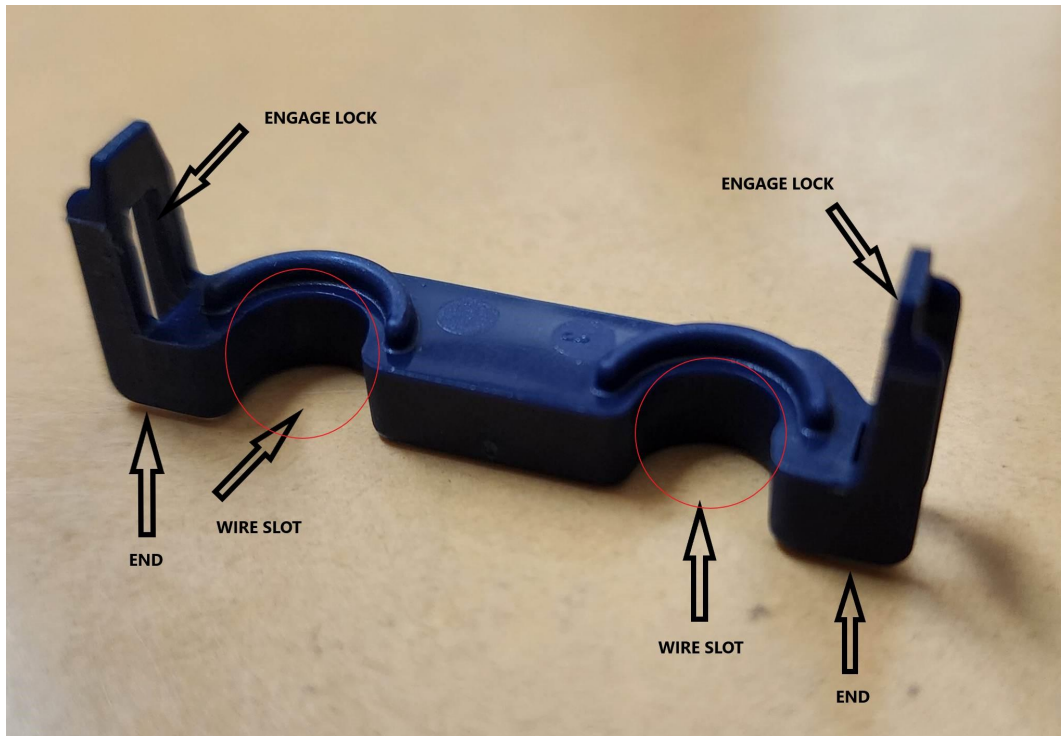

Lining up the wires in the wire slots on the TPA:

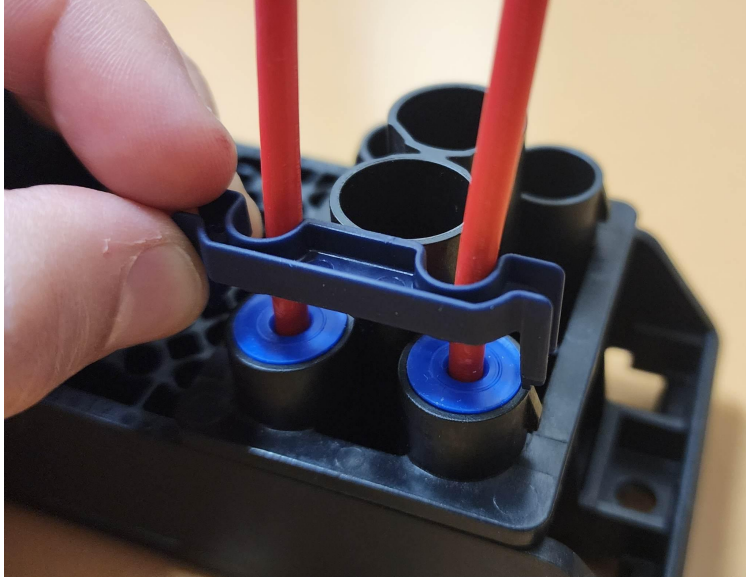

Ends pushed in and sliding into base:

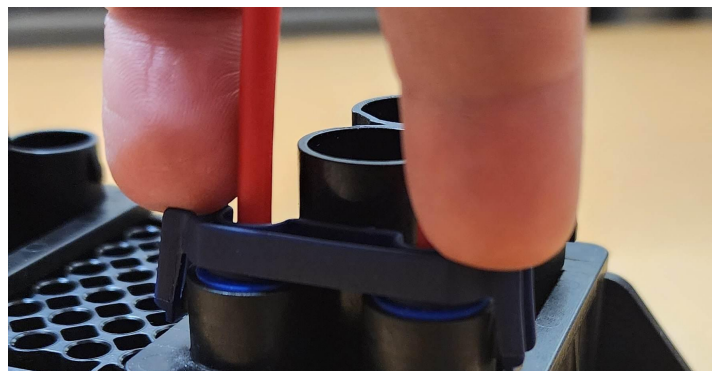

Screwdriver being used to aid in installation:

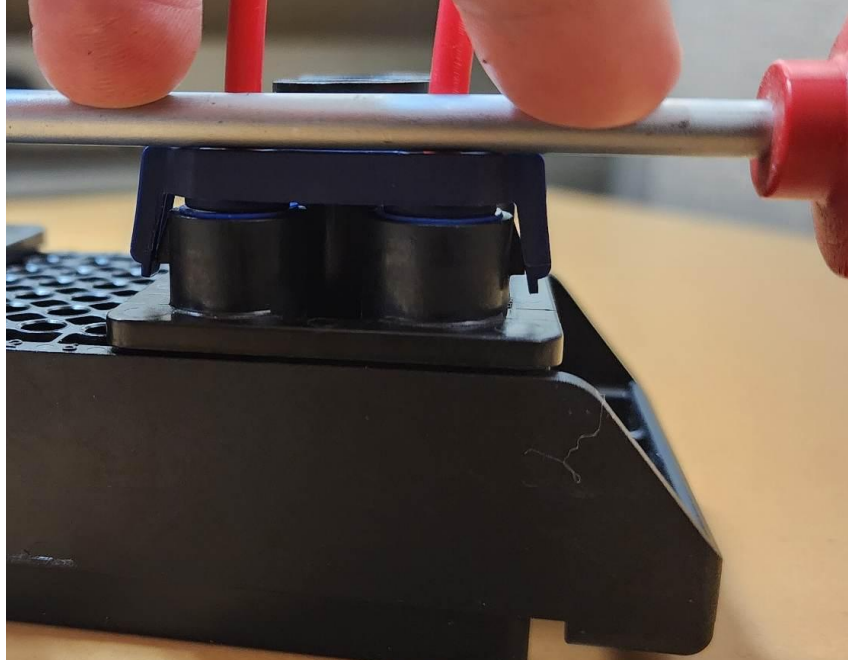

Improper Installation

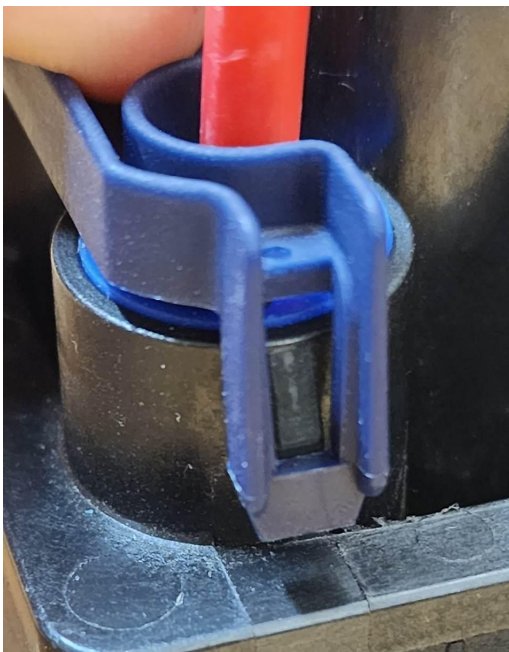

Proper Installation

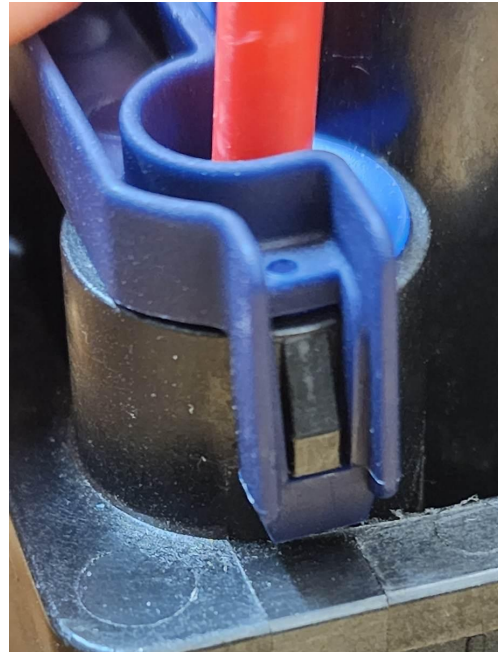

CPA Locking Method

By pushing down on the middle of the CPA, it will snap into its position and make a distinct clicking noise when it is properly locked. When the CPA's are locked they will prevent the locking clips from disengaging when they are pressed in. See below for pictures showing the locked and unlocked positions.



Disassembly Instructions

280 TPA Disassembly

Once the TPA is locked into position, it can only be removed with a tool. Use a small screwdriver (or similar tool) and a small hammer. With the screwdriver, push on the ledge of one side of the TPA on an angle as shown in the pictures below. Using the small hammer, tap on the end of the screwdriver until the ledge of the TPA is knocked from its locking position, disengaging that end of the TPA from the base. Repeat this process on the other end to fully disassemble the TPA from the base. A removed TPA should not be reused.

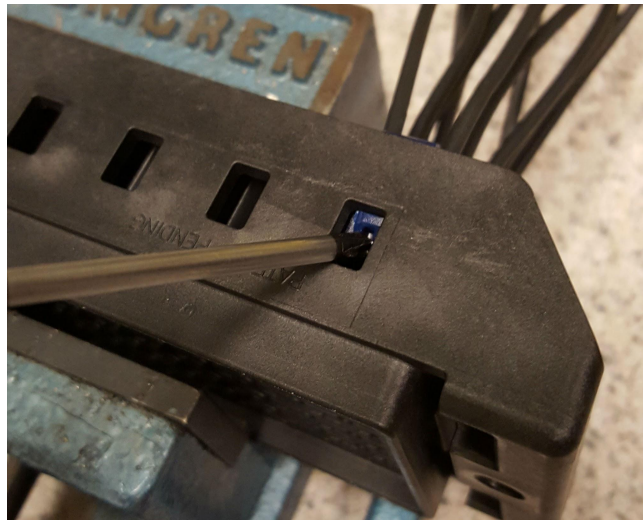

P1049 TPA Disassembly

Once the TPA is locked into position, it can only be removed with a tool. Use a small screwdriver (or similar tool) and a small hammer. With the screwdriver, push on the ledge of one side of the TPA on an angle as shown in the pictures below. Using the small hammer, tap on the end of the screwdriver until the ledge of the TPA is knocked from its locking position, disengaging that end of the TPA from the base. Repeat this process on the other end to fully disassemble the TPA from the base. A removed TPA should not be reused.



P345 TPA Disassembly

Once the TPA is locked into position, it can only be removed with a tool. Use a small screwdriver (or similar tool). With the screwdriver, push on the ledge of one side of the TPA on an angle as shown in the pictures below. Gently tap on the end of the screwdriver until the ledge of the TPA is knocked from its locking position, disengaging that end of the TPA from the base. Repeat this process on the other end to fully disassemble the TPA from the base. A removed TPA should not be reused.



Cover Disassembly Method

To remove the cover when it is fully locked into the base, first make sure the CPA's are in their unlocked position. The cover can be taken off by pressing each locking tab until a clicking noise is made, disengaging that locking clip from the base. The easiest way to remove the cover is to press two of the locking clips on opposite ends and then move on to the other two locking clips. See below for a picture demonstrating the easiest method to remove the cover.



Terminal Systems

Example part numbers are shown in the table below, this table is for reference only -- the latest information is available from the terminal manufacturers. Note that x- and -x represent material, plating, or tooling options.

MCP 2.8						
Cavity Plug: 828922-1						
Terminal Extraction Tool: 1-1579007-2						
Wire Size mm ² (AWG)	Insulation Diameter (mm)	Strip Form	Loose Piece	Applicator Tool	Hand Crimp Tool (Die Set)	Single Wire Seal
0.35 - 0.50 (22 - 20)	1.2 - 1.4	x-968882-x	x-968896-x	2151559-x	539725-2	828904-1
0.5 - 1.0 (20 - 18)	1.4 - 2.1	x-968855-x	x-968875-x	2151227-x	539726-2	828904-1
1.0 - 2.5 (16 - 14)	2.2 - 3.0	x-968857-x	x-968876-x	2151346-x	539727-2	828905-1
3.3 (12)	3.0 - 3.2	x-1719506-x	-	-	539727-2	638865-1



TD-103 - BRIC Application Specification

©Chief Enterprises 2022
Rev: 14-MAR-2023

Page 25/33

May not be distributed or reproduced without written permission

WWW.CHIEFENT.COM

MCP 6.3						
Cavity Plug: 967652-1						
Terminal Extraction Tool:1-1579007-3						
Wire Size mm ² (AWG)	Insulation Diameter (mm)	Strip Form	Loose Piece	Applicator Tool	Hand Crimp Tool (Die Set)	Single Wire Seal
0.50 - 1.0 (20 - 18)	2.0 - 2.1	x-1241412-x	x-1241413-x	2151234-x	539955-2	1394511-1
>1.0 - 2.5 (16 - 14)	2.2 - 2.7	x-1241414-x	x-1241415-x	2151177-x	539956-2	1394511-1
>2.5 - 4.0 (12)	3.4 - 3.7	x-1241416-x	x-1241417-x	2151151-x	539956-2	1394512-1
>4.0 - 6.0 (10)	4.0 - 4.5	x-1241418-x	x-1241419-x	2151466-x	3-1579021-7	1719043-1



TD-103 - BRIC Application Specification

©Chief Enterprises 2022
 Rev: 14-MAR-2023

Page 26/33

May not be distributed or reproduced without written permission

WWW.CHIEFENT.COM

MCP 9.5						
Cavity Plug: P1036-1						
Terminal Extraction Tool: 539971-1						
Wire Size mm ² (AWG)	Insulation Diameter (mm)	Strip Form	Loose Piece	Applicator Tool	Hand Crimp Tool (Die Set)	Single Wire Seal
6.0 - 10.0 (8)	4.6-5.2	x-967590-x	x-929152-x	2151794-x	539783-8	1355437-1
6.0 - 10.0 (8)	5.8-6.6	x-967590-x	x-929152-x	2151794-x	539783-9	1355437-2
10.0-16.0 (6)	7.1 - 8.1	x-967591-x	x-929153-x	9-541710-2	1-539783-0	1355437-3



TD-103 - BRIC Application Specification

©Chief Enterprises 2022
 Rev: 14-MAR-2023

May not be distributed or reproduced without written permission

Delphi Metri Pack 800						
Cavity Plug: P693						
Terminal Extraction Tool: 12094429						
Wire Size mm ² (AWG)	Insulation Diameter (mm)	Strip Form	Loose Piece	Applicator Tool	Hand Crimp Tool	Single Wire Seal
5.0 (10)	3.61-5.33	15336748	15336748-L	Inquire for details	15370042	15324999 or 15324998
8.0 (8)	4.5-5.79	12129414	12129414-L	Inquire for details	15370042	15324998



TD-103 - BRIC Application Specification

©Chief Enterprises 2022
Rev: 14-MAR-2023

May not be distributed or reproduced without written permission

Page 28/33

WWW.CHIEFENT.COM

Electrical & Environmental

Ambient Temperature:	-40 to 120 °C
Max Current per Terminal:	30 Amps Intermittent 20 Amps Continuous (with temperature derating)
Max Continuous Current per PDM:	With Vent: 360 A Without Vent: 300 A (for IP rating)
Max Intermittent Current per PDM:	Must be determined by customer
Water & Dust Ingress Protection:	IP 67
Wire Range:	24 to 12 AWG
Environmental Compatibility:	Resistant to most underhood chemicals, UV Stable
Compliance:	ROHS Cover: UL 94HB Body: UL 94V-0 Seal: UL 94HB
Materials:	Cover: PPE + PA Body: Glass Reinforced PBT Seal: Silicone
Design Recommendations:	Place heat-generating components on perimeter Maximize wire gauge for heat dissipation Mount in area with airflow, away from heat sources

Temperature Derating using MCP 2.8 Terminals

The PDM materials can withstand high temperatures before degradation, but Chief does not recommend exceeding 120 °C for any components or the PDM itself.

Thorough testing has demonstrated the relationship between temperature and current on a PDM with properly specified wire gauges. At no point should the base or interior components be exposed to temperatures exceeding 120 °C, or the maximum component temperature, whichever is lower. For example, a 48-way PDM with 15A per circuit continuous (24 circuits of 15A each) should be in ambient temperature below ~77 °C.

The chart below shows this as a derating for MCP 2.8 terminals. Note that temperature derating has not been performed on other terminals used in BRIC Fusion.

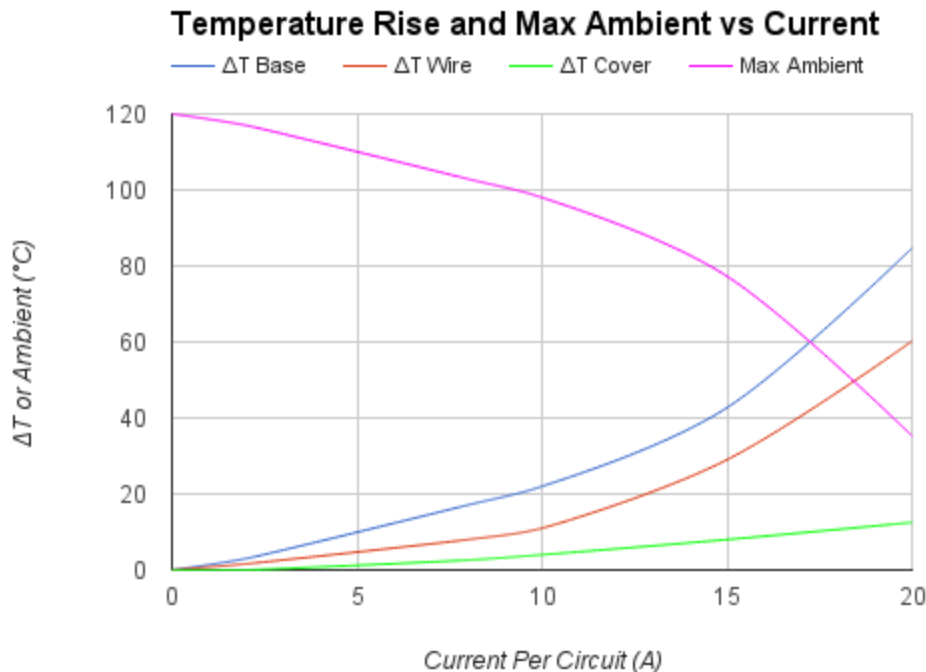

Validation Testing

Combined Temperature Vibration HALT: ▪	-40 to 125 °C plus vibration
High temperature Soak: ▪	125 °C (Operational)
Low Temperature Soak: ▪	-40 °C (Operational)
Temperature Cycle: ▪	-40 to 125 °C, 10 Cycles (Operational)
Temperature Shock: ▪	-40 to 90 °C, 100 Cycles (Operational)
Drop Test: ▪	1 Meter onto Hardwood, All Sides
Vibration: ▪	Random 100 hrs (Operational)
Particle Impact: ▪	Simulated Gravel
Water & Dust Ingress: ▪	IP 67
Combined Temperature & Humidity: ▪	100 Hours (Operational)
Salt Spray: ▪	96 Hours
Chemical Resistance: ▪	Oils, Fertilizer, Urea, NPK
Ozone: ▪	70 hours
Accelerated Weathering (Ultraviolet): ▪	2,000 Hours

▪ complete & passed

▫ in process/planned

Accessories & Options



TPA



CUSTOM LABELS



TPA -
EXTERNAL
MOUNT



STAINLESS
STEEL TETHER
WITH TERMINAL
RING



ERGONOMIC
CPA



TETHER



SIDE MOUNT

Required for most BRIC

- Foam - Provides anti-backout pressure on tall components. Required for all applications with relays, circuit breakers, diodes, or other 25mm tall components. Not required for applications with only ATM or ATO fuses. Not recommended with manual reset circuit breakers.

Required for BRIC Fusion with Maxi Fuses

- Metripack 800 TPA - Terminals are single tang.

Optional for 280 BRIC

- 280 TPA - MCP terminals are dual tang and have sufficient pullout retention.

Optional for all BRIC

- CPA - Prevents accidental unlocking of cover. Without CPA's, IP rating of BRIC may be less than IPx7 due to water pressure disengaging snap fits
- Breather - Equalizes pressure, minimizing risk of water intrusion. Not directly applicable to IP ratings.
- Seal - Creates barrier between cover and base. Without seal, IP rating is approx IP33.
- Tether
- Diode Key
- Universal Brackets
- Labels
- Laser Marking

Custom Laser Marking

Chief provides custom laser marking on the covers of all sizes of the BRIC. Logos, instructions, schematics, lot codes, and other markings can be per your specification they can be added within the red boundaries mark below(see image).

Our laser marking is a permanent, high resolution monochromatic/grayscale, but can be prone to abrasion and is not meant to be UV resistant. Text size is legible to 1.0 mm height. Submit artwork in any standard electronic format.

